

The
POWER *In*
PRESENTATION PRODUCTS



Instruction Book for
SERIES 200 AND 300
LACE AND GROMMET FRAME



DA-LITE SCREEN COMPANY, INC.

3100 North Detroit Street
Post Office Box 137
Warsaw, Indiana 46581-0137
Phone: 574-267-8101
800-622-3737
Fax: 574-267-7804
Toll Free Fax: 877-325-4832
www.da-lite.com
e-mail: info@da-lite.com

INSTALLATION

FRAME ASSEMBLY

You will need a 9/16" wrench to assemble your Series 200/300 lace and grommet frame. If you have a split frame, you will also need a 3/16" allen wrench. Before beginning assembly make sure the work surface is clear of objects or debris that could scratch the frame or puncture the viewing surface. Use the wrapping material to lay the frame sections on to keep from scratching the frame.

1. Unwrap the frame sections and orient them as shown in the Figure below. Note that the ends are color coded. Make sure the colors match at each corner. If your frame has the optional Pro-Trim masked borders, lay the frame with the borders facing down. Be sure to lay the frame on the wrapping material to keep the Pro-Trim clean.
2. If your frame has two-piece top and bottom frame sections, match the color codes on the ends of the tubes. See split frame assembly on page 3. When top and bottom sections are assembled the corners should lay flat to assure that the unit does not twist or bow.
3. Slide the side frame sections onto the top frame section. Insert one 3/8" bolt at each corner and tighten (do not over-tighten).
4. The next step is much easier with two people. With one person at each end, slide the bottom frame section into the side frame sections. Make sure each side slides evenly to avoid binding. Insert one 3/8" bolt at each corner and tighten (do not over-tighten).
5. Frame assembly is complete. Next, unwrap the viewing surface (sold separately) and lay it face down inside the frame assembly.
6. The viewing side of the surface is wrapped to the inside of the roll so you will have to unroll the surface and then turn it over. Be sure to lay the surface on the wrapping material to keep it clean.
7. Start at one side of the frame and locate the center of the viewing surface and frame. The center of the screen surface can be identified by a bright colored grommet on each of the four sides. The center of the frame is marked by a piece of colored tape. Starting at the center, begin attaching the hooks on the frame into the grommets holes in the screen surface. When you get to one end, the grommet in the corner of the viewing surface should be attached to the s-hook in the corner of the frame.

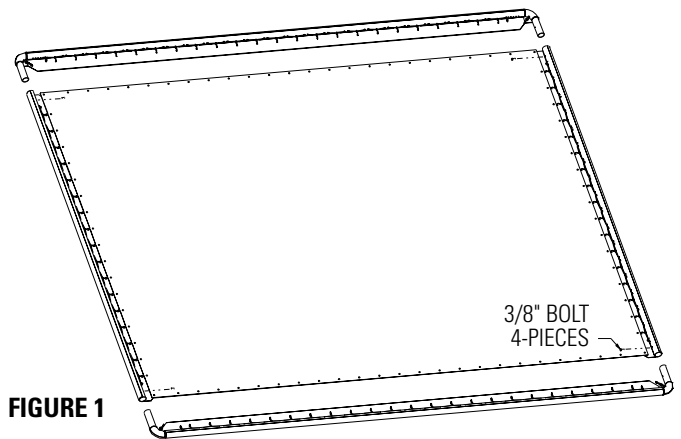

FIGURE 1

SERIES 200 INSTALLATION

The Series 200 frame is supplied with eyebolts for ceiling installations and hanger brackets for wall mount installations.

Ceiling installation: The frame is predrilled for the attachment of the eyebolts. There are 3 eyebolts for smaller frames with a one-piece top frame rail. Larger frames with two-piece top frame rails will have 4 eyebolts. Insert the eyebolts through the frame and attach the hex nut to the eyebolt.

Wall mount installation: There are 6 hanger brackets for smaller frames with a one-piece top frame rail. 8 hanger brackets are provided for larger frames with two-piece top frame rails. Determine where the Series 200 frame will be mounted on the wall. Consider the following before attaching the hanger brackets to the wall.

- The hanger brackets must be anchored to a supported section of the wall, such as a wall stud.
 - The hanger brackets should be spaced on the wall so they line up with the S-hooks on the frame. This will prevent the lace cord from being pinched between the frame and hanger.
 - You will need at least 2" above the hanger bracket to mount the Series 200 frame (see Figure 2).
 - Frames with one-piece top frame rails should be supported at the center of the frame and about 2-4 feet from each end of the frame.
 - Frames with two-piece top frame rails should be supported about 2-3 feet on each side of the center joint and about 2-4 feet from each end of the frame.
1. Attach 3 or 4 hanger brackets (as required above) at the same height along the wall. To determine the distance between the upper and lower hanger brackets you must measure the overall height of the frame. If your frame has the Pro-Trim border subtract 3-3/4" from the overall height. If your frame does not have the Pro-Trim border subtract 3-1/2" from the overall height. Using this number, measure down from each hanger bracket and mark the wall.

SERIES 200 INSTALLATION (CONTINUED)

2. Line up the lower hanger bracket with the mark and secure it to the wall. Refer to Figure 2.
3. Remove the frame clamp from the hanger brackets and position the Series 200 frame on the hanger brackets as shown in Figure 2.
4. Place the frame clamp onto the hanger bracket and secure it with the supplied hex nut.

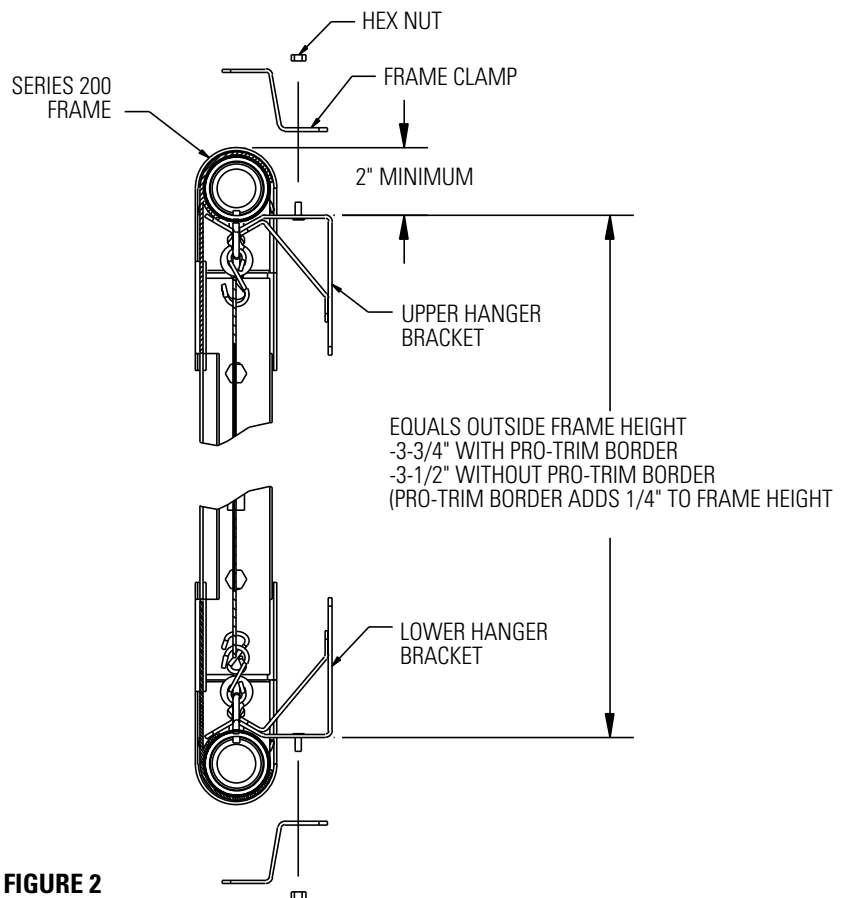

FIGURE 2

SERIES 300 INSTALLATION

The Series 300 frame is supplied with eyebolts for ceiling installations and hanger brackets for wall mount installations.

Ceiling installation: The frame is predrilled for the attachment of the eyebolts. There are 3 eyebolts for smaller frames with a one-piece top frame rail. Larger frames with two-piece top frame rails will have 4 eyebolts. Insert the eyebolts through the frame and attach the hex nut to the eyebolt.

Wall mount installation: There are 6 hanger brackets for smaller frames with a one-piece top frame rail. 8 hanger brackets are provided for larger frames with two-piece top frame rails. Determine where the Series 300 frame will be mounted on the wall. Consider the following before attaching the hanger brackets to the wall.

- The hanger brackets must be anchored to a supported section of the wall, such as a wall stud.
- The hanger brackets should be spaced on the wall so they line up with the S-hooks on the frame. This will prevent the lace cord from being pinched between the frame and hanger.
- You will need at least 3" above the hanger bracket to mount the Series 300 frame (see Figure 3).
- Frames with one-piece top frame rails should be supported at the center of the frame and about 2-4 feet from each end of the frame.
- Frames with two-piece top frame rails should be supported about 2-3 feet on each side of the center joint and about 2-4 feet from each end of the frame.

1. Attach 3 or 4 hanger brackets (as required above) at the same height along the wall. To determine the distance between the upper and lower hanger brackets you must measure the overall height of the frame. If your frame has the Pro-Trim border subtract 4-3/4" from the overall height. If your frame does not have the Pro-Trim border subtract 4-1/2" from the overall height. Using this number, measure down from each hanger bracket and mark the wall.

SERIES 300 INSTALLATION (CONTINUED)

2. Line up the lower hanger bracket with the mark and secure it to the wall. Refer to Figure 3.
3. Remove the frame clamp from the hanger brackets and position the Series 300 frame on the hanger brackets as shown in Figure 3.
4. Place the frame clamp onto the hanger bracket and secure it with the supplied hex nut.

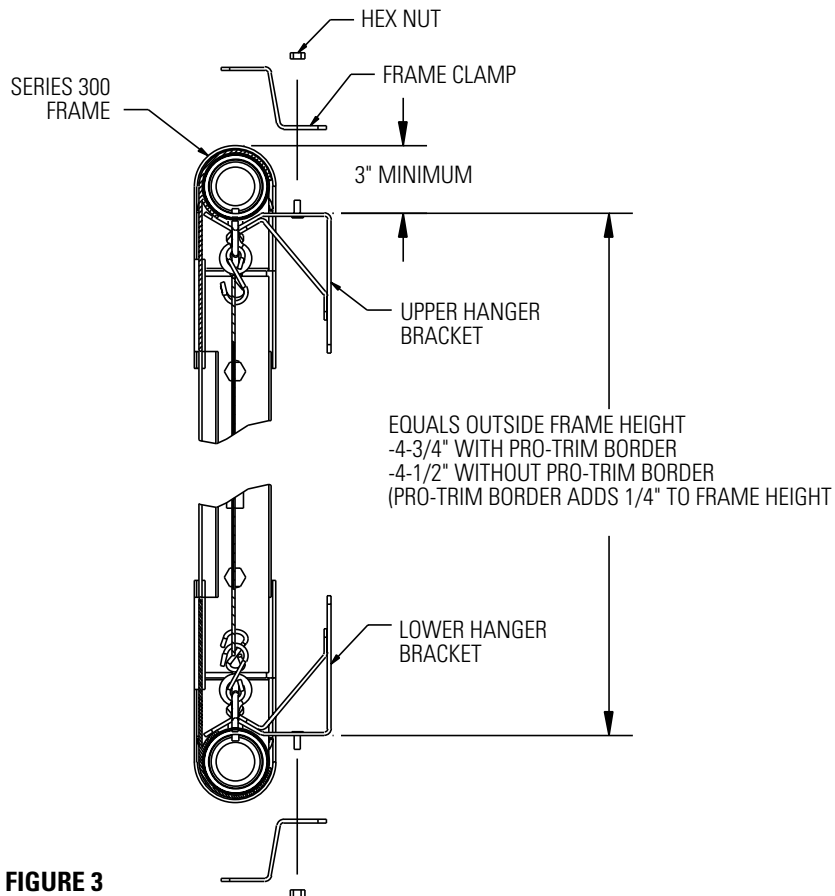

FIGURE 3

SPLIT FRAME ASSEMBLY

1. Loosely tighten set screw so that pieces will still move freely. See Figure 4.
2. Slide tube over connector and line up hole. See Figure 5.
3. Insert second set screw and tighten all the way until tube is secure. See Figure 6.
4. Tighten first set screw the rest of the way. See Figure 6.
5. Finished joint should look like Figure 7.

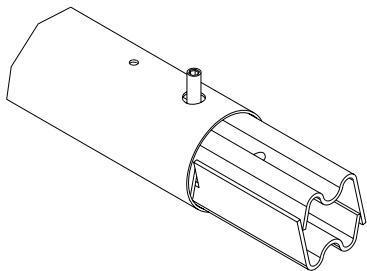

FIGURE 4

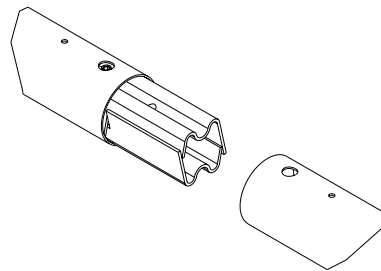

FIGURE 5

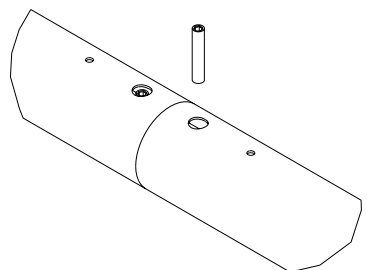

FIGURE 6

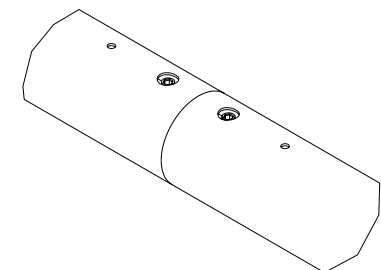

FIGURE 7